

PT-6 100 HOUR INSPECTION KIT

**FOR AIRCRAFT WITH
PWC PT-6 ENGINE**

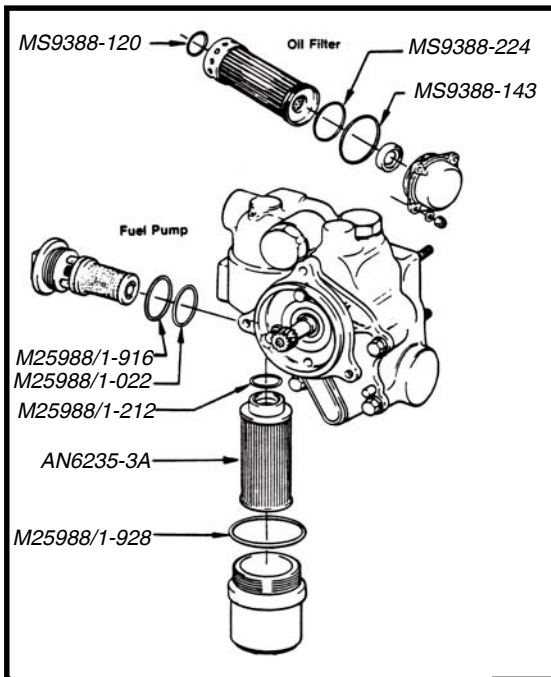

* Contains all the necessary "O" rings for chip detector, fuel pump, P3 filter & oil filter

* Contains "O" rings for Airmaze and Purolator Firewall fuel strainers

* Universal kit can be used on the following aircraft:

Beech King Air 90	DeHavilland Dash 7
Beech King Air 100	DeHavilland Twin Otter
Beech King Air 200	Embraer EMB 110
Beech B1900	Piper PA31T, -1, PA42
Cessna 208 Caravan	Short Bros. SD330/SD360
Cessna 425	

Check Aircraft Manufacturers IPC for installation eligibility

AN6235-3A	Filter, Fuel	MS9388-224	O Ring, Oil Filter
MS9388-015 or M83248/1-015	O Ring, P3 Filter	M25988/1-022	O Ring, Oil Filter (99-4346-22), "O" Ring Fuel Filter (99-4347-16), "O" Ring Fuel Filter (99-4684-28), "O" Ring Fuel Filter (99-4685-212), "O" Ring Fuel Filter
MS9388-019 or M83248/1-019	O Ring, Forward Oil Filter	M25988/1-916	O Ring, Fuel Strainer, Airmaze
MS9388-115 or M83248/1-115	O Ring, Chip Detector	M25988/1-928	O Ring, Fuel Strainer, Airmaze
MS9388-120 or M83248/1-120	O Ring, Oil Filter	M25988/1-212	O Ring, Fuel Strainer, Purolator
MS9388-126 or M83248/1-126	O Ring, P3 Filter	AN123962	O Ring, Fuel Strainer, Purolator
MS9388-143 or M83248/1-143	O Ring, Oil Filter	AN123992	
		MS29513-148	
		7500-5/16	

Note: This is a Universal Kit for the PT-6 engine. Depending on the application, not all "O" rings will be needed.

If there is a black "O" ring in the AN6235-3A filter, it should be replaced with the kit "O" ring M25988/1-212 which is blue in color.

RAPCO, inc.

REPLACEMENT AIRCRAFT PARTS CO.

445 Cardinal Lane
Hartland, Wisconsin 53029 USA
For a list of Distributors, please call.
(262) 367-2292 Phone (262) 367-7158 Fax
www.rapcoinc.com

